

A septic tank is a critical part of almost all onsite wastewater systems. In order for a septic tank to work effectively and to protect the rest of the wastewater system, it must be pumped (emptied) periodically. Material pumped from the septic tank is known as “septage.” This bulletin describes septic tank pumping, pumping frequency and other procedures to maintain a properly functioning septic tank.

The Purpose of a Septic Tank

The purpose of a septic tank is to remove, store, and decompose as much of the solid part of the wastewater as possible before the wastewater goes to the absorption field or enhanced treatment unit. This helps protect the absorption field or treatment system from clogging and premature failure.

The septic tank is a concrete, heavy-duty fiberglass, or plastic tank that should be watertight and large enough so solids have time to separate from the wastewater. While the wastewater is in the tank, heavier material settles to the bottom and lighter material, such as oil and grease, rises to the top as shown in Figure 1. The material on the bottom is called sludge and that on the top is called scum.

Twenty-four hours is the minimum detention time even with sludge and scum accumulation. An empty tank should be sized to contain at least two to three

times the daily flow. As wastewater flows through the tank between the sludge and scum layers, solids separate and the wastewater becomes nearly clear. Biological action known as anaerobic digestion decomposes some of the solids into simpler compounds such as water and gases.

The Purpose of Pumping

Properly sized tanks have enough space for sludge to accumulate for several years without interfering with solids separation from the wastewater. As sludge accumulates, increasingly less space and time are available for the solids to separate before wastewater leaves the tank. Sludge solids near the clear liquid zone are very light and are easily resuspended. As solids accumulate and shorten the detention time, some solids are carried out of the tank and into the soil absorption field. Solids cause the soil absorption field to gradually plug and finally fail, causing sewage to back up in the house or effluent to surface outside. Pumping the septic tank periodically prevents solids from being carried out of the septic tank, causing premature failure of the system. Whenever possible, install a larger tank than the minimum size required in the permit.

Safety Precautions

It should never be necessary to enter a septic tank that has been used. Digestion of the waste produces toxic gases that can kill a person in a matter of minutes. A mirror and a flashlight can be used to examine the interior without entering the tank. Any work to repair the tank or to replace the baffles should be done from the outside. When working on a tank, make sure that it is well ventilated and that someone is standing by to provide emergency assistance.

If entering the tank becomes necessary, never do so without wearing a self-contained breathing apparatus (SCBA). If someone has fallen in and is overcome by toxic gases or the lack of oxygen and a SCBA is not available, do not enter the tank. The best thing to do is to call for emergency services and put a fan at the top of the tank to blow in fresh air.

Figure 1. Cross Section of a Septic Tank

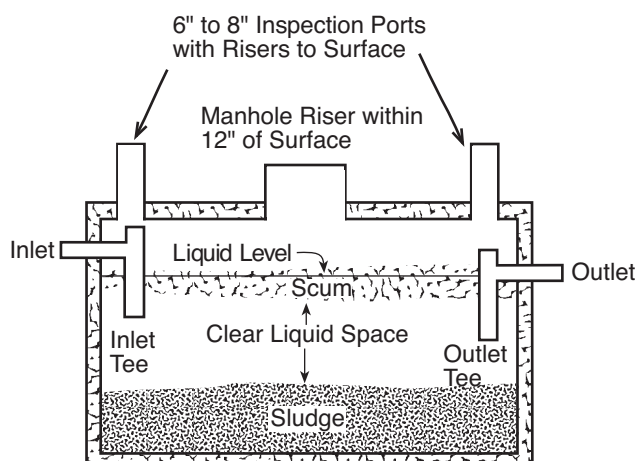

After exposure to the contents of a septic tank, thoroughly wash skin and clothing that may have come in contact with the contents. Wastewater may contain microorganisms that cause disease.

Pumping Frequency

The frequency of pumping depends on the following factors:

- capacity of the septic tank
- quantity of wastewater (number of people and water use habits)
- volume of solids in wastewater (more solids if a garbage disposal is used)

Table 1 shows estimated pumping frequencies for various septic tank capacities and number of people served. The frequencies were calculated to provide a minimum of 24 hours of wastewater detention assuming 50 percent digestion of the retained solids, 50 gallons of sewage per person per day and no garbage disposal. If wastewater flow is more than 50 gallons per person per day, increase the pumping frequency accordingly. If a garbage disposal is used, the time between pumpings should be decreased by about one-third.

In Kansas, a minimum 1,000-gallon septic tank is recommended for a home with 3 bedrooms.¹ According to Table 1, if 6 people live in a house with a 1,000-gallon tank, the tank should be pumped about

Table 1. Estimated Septic Tank Pumping Frequencies in Years (Year-Round Residence)

Tank Size (gal)	People in Household						
	1	2	3	4	6	8	10
500	5.8	2.6	1.5	1.0	0.4	0.2	—
750	9.1	4.2	2.6	1.8	1.0	0.6	0.3
900	11.0	5.2	3.3	2.3	1.3	0.8	0.5
1,000	12.4	5.9	3.7	2.6	1.5	1.0	0.7
1,250	15.6	7.5	4.8	3.4	2.0	1.4	1.0
1,500	18.9	9.1	5.9	4.2	2.6	1.8	1.3
1,750	22.1	10.7	6.9	5.0	3.1	2.2	1.6
2,000	25.4	12.4	8.0	5.9	3.7	2.6	2.0
2,250	28.6	14.0	9.1	6.7	4.2	3.0	2.3
2,500	31.9	15.6	10.2	7.5	4.8	4.0	2.6

Notes: More frequent pumping is needed if a garbage disposal is used.

Shaded area covers pumping frequencies for tanks that are smaller than minimum recommended sizes.

every 1.5 years. After each time the septic tank is pumped, consult with the pumper as to whether the tank should have been pumped sooner or whether it could have waited longer. Use this information to estimate when the tank should be pumped the next time. However, if the wastewater production changes because of changes in number of family members or adding a garbage disposal, adjust the pumping frequency accordingly.

Determining Sludge and Scum Buildup

The best way to determine whether a septic tank needs to be pumped is to measure the levels of sludge and scum rather than relying on a chart. A homeowner can use the method described below and illustrated in Figure 2. A septage pumper may have a device that locates the layers by measuring changes in light transmission.

Measuring sludge depth. Use a stick long enough to reach the bottom of the septic tank from the surface (at least 8 feet long). Wrap the bottom 4 feet of the stick with a light-colored bath towel or similar material. The material should be firmly attached to the stick so it does not shift or come loose. Remove the manhole cover nearest the outlet end of the tank. If the outlet is a baffle, “Tee,” or flat vertical plate with an opening at the top, run the measuring stick down through the opening to the bottom of the tank. If the outlet is an elbow type with no top opening, make a hole in the scum mat near the outlet, then lower the measuring stick through the hole. With downward pressure, slowly rotate the measuring stick a couple of times to make sure it is at the bottom, mark the stick at a convenient reference point such as the top of the tank (Mark A), wait a couple of minutes, and slowly lift it straight out of the tank. The sludge layer can be distinguished from the liquid by the black particles clinging to the towel. The length of the black portion indicates the sludge depth. The distance between Mark A and the highest black particle is the distance to the top of the sludge.

Measuring scum thickness. To determine scum accumulation, attach the side of a 3-inch square piece of wood firmly to the end of a long stick, making it look like a large “L.” Push the measuring device through the scum layer into the liquid layer. As the stick is carefully moved up against the scum layer, a

¹In areas without a county sanitary code, KDHE *Bulletin 4-2: Minimum Standards for Design and Construction of Onsite Wastewater Systems* requires that septic tanks have at least 1,000 gallon capacity.

change in resistance will be felt, indicating the bottom of the scum layer. Mark the stick at the same reference point used before (Mark B). With the same device locate the bottom of the outlet baffle and re-mark the stick at the same reference point (Mark C).

The distance between Marks B and C is the distance between the bottom of the scum layer and the bottom of the outlet baffle. Place the two sticks with reference Marks A and C together. Measure from the projection on the "L" to the top of the sludge particles to find the distance between the sludge and the bottom of the outlet.

It is time to pump a septic tank when the bottom of the scum layer is less than 3 inches above the bottom of the outlet baffle or when the top of the sludge layer is within 12 inches of the bottom of the baffle.

Pumping Procedures

Septage pump-and-haul contractors are equipped to remove septage from the tank. It is a good idea to understand the process to help ensure that it is done properly. To remove all the material from the tank, the scum layer must be broken up and the sludge layer mixed into the liquid. This usually involves alternately extracting liquid from the tank and reinjecting it into the tank to suspend accumulated, compacted sludge. The septic tank should be pumped out through the large manhole, not through the small inspection ports.

Pumping through the inspection ports may damage the baffles or "Tees." If the tank has two or more compartments, or if there are multiple tanks, be sure all spaces are pumped. If the system has a separate pump chamber or an aeration system chamber, these should be pumped as well. If the tank is equipped with an effluent filter, it should be removed, cleaned (usually by rinsing the filter with a hose held over the septic tank manhole), and inspected for damage before replacing it. Information from the manufacturers will provide guidance on how and when to clean these additional units.

With the tank open, the contractor should check the condition of the interior of the tank and the baffles or "Tees." If the inside surfaces of the tank are "crusty" or soft, the concrete is deteriorating. If roots are visible inside the tank, it has leaks. In either case, if the tank cannot be repaired so that it is watertight, it should be replaced. If a baffle has deteriorated or is missing, install new sanitary tees. To facilitate inspection and pumping, install risers from the manhole and inspection ports to within 12 inches of the surface before burying the access hole cover. Also, permanently mark the location of the tank or make a sketch map with distances and directions from permanent above-ground landmarks to the tank for easy future location.

Figure 2. How to Determine Distance from Septic Tank Outlet to Sludge and Scum Layers

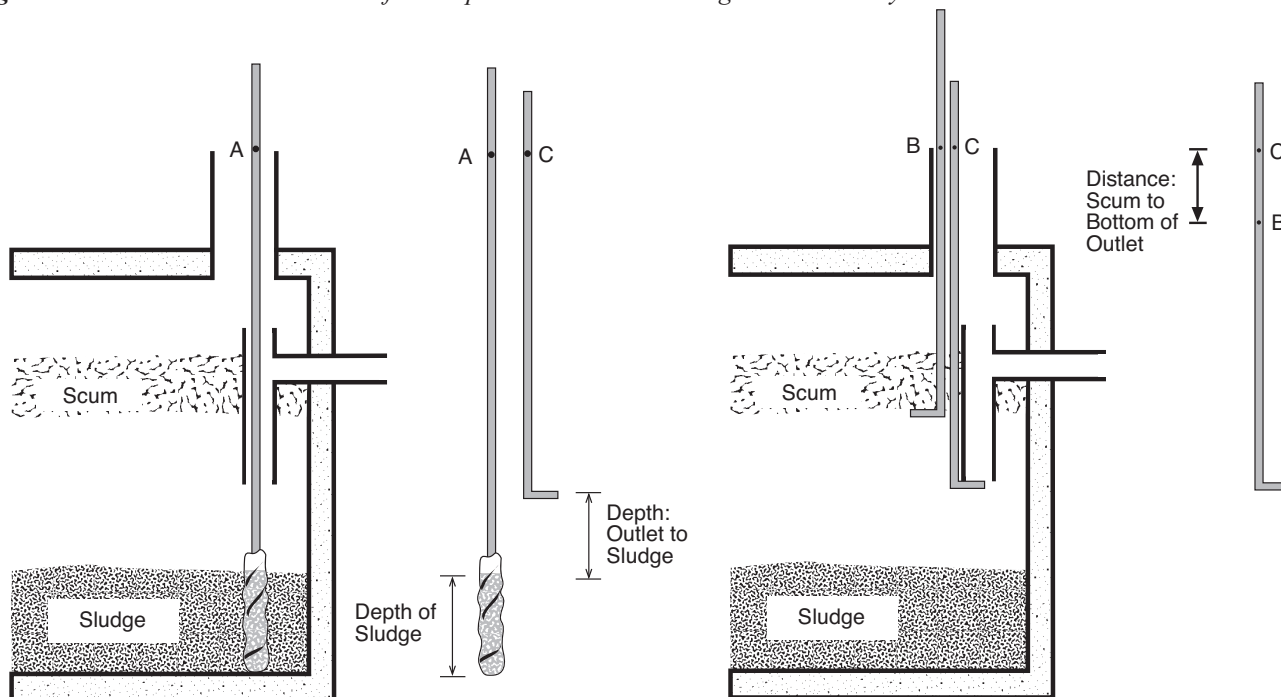

Solids Disposal

It is the septic system owner's responsibility to be sure that the materials removed from the septic tank are disposed of legally. The U.S. Environmental Protection Agency has regulations (40 CFR – Part 503) that describe the requirements for disposing of solid materials from wastewater systems, both public and private. There are several legal disposal options such as transferring to a municipal wastewater treatment plant, applying to land and tilling into the soil, sub-surface injection into soil, and treatment followed by landfilling. Choose a pumper who is licensed by the local agency, disposes of septage legally and safely, and keeps accurate records. If you have questions, contact your local health department or the Kansas Department of Health and Environment district office.

Improving Septic System Operation and Protecting the System

Some materials do not decompose in the septic tank and take up valuable sludge storage capacity. Avoid putting the following down the drain: fats, oils, grease, egg shells, coffee grounds, facial tissues, disposable dish rags and diapers, lint from mops or washing machines, hair, cigarette butts, sand, soil from garden vegetables or other sources, bones, or other nondegradable items such as plastic, fabric, glass, and metal. Liquid laundry detergents are preferable to powdered forms, because the powders contain bulking agents that do not readily break down.

Materials Not to Put Down the Drain

The following materials do not adequately decompose in the septic system and contaminate groundwater: solvents, degreasers, excessive disinfectants, paint, waste chemicals, pesticides, poisons, and similar materials.

Additives

Additives for the septic tank are highly promoted. They claim to make the system function better and eliminate the need to pump the tank. If the additives work as advertised, they may reduce the amount of material in the septic tank, which means it will be transferred to the absorption field where it may hasten failure of the absorption field. This process works against the purpose of a septic tank which is to keep as much solid material in the septic tank as possible to protect the soil absorption system.

An effluent filter improves the septic tank's efficiency of solids removal. It is a screened device that usually fits in the outlet "Tee" and protects the soil absorption field from solids carryover. Some filters are designed to be cleaned annually and others are large enough to be cleaned when the septic tank is pumped.

For more information on septic systems, contact your local health department, county Extension office, or Kansas Department of Health and Environment.

Grateful acknowledgement is made to the original authors: Barbara L. Dallemand and G. Morgan Powell, Extension engineers in the areas of onsite wastewater systems and water quality.

Revised by Judith M. Willingham, extension assistant, Bio and Ag Engineering.

Publications from Kansas State University are available at: <http://www.bookstore.ksre.ksu.edu>

Date shown is that of publication or last revision.

Contents of this publication may be freely reproduced for educational purposes. All other rights reserved. In each case, credit Judith M. Willingham, *Septic Tank Maintenance: A Key to Longer Septic System Life*, Kansas State University, August 2010.