



# Nozzle Types for Boom Sprayer Applications of Crop Protection Products

Robert E. Wolf, Extension Agricultural Engineer, Kansas State University  
 Dennis R. Gardisser, Extension Agricultural Engineer, University of Arkansas  
 John Slocombe, Extension Agricultural Engineer, Kansas State University  
 Bryan W. Shaw, Extension Agricultural Engineer, Texas A & M University

Regardless of the type of application system and cost, selecting the correct type and size of spray nozzle is essential. The nozzle determines the amount of spray applied to an area, the uniformity of the application, the coverage of the sprayed surface, and the amount of drift. Drift can be minimized by selecting nozzles that produce a large droplet spectrum, while providing adequate coverage at the intended application rate and pressure. All nozzles develop a range of droplet sizes. Those that develop the least amount of fines are least drift prone. Although nozzles have been developed for practically every kind of spray application, only a few are commonly used in crop protection product applications. Emphasis in nozzle design during the past few years has resulted in a vast improvement in spray quality. A few commonly used nozzles are described in this publication.

## Nozzle Types

**Extended Range Flat-Fan (has essentially replaced regular and low-pressure flat-fan, available from all nozzle manufacturers)**

*Extended or total range flat-fan nozzle*

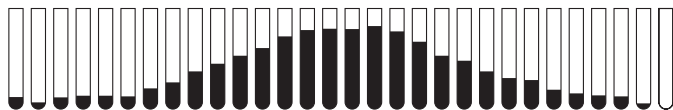

*Extended range flat-fan spray pattern*

Extended range flat-fan nozzles are frequently used for soil and foliar applications when better coverage is required. Extended range flat-fan nozzles are available in 80- and 110-degree fan angles. The spray pattern produced by this nozzle has a tapered edge distribution. The outer edges of the spray pattern have reduced volumes. This makes it necessary to overlap adjacent patterns along a boom to obtain uniform coverage. Eighty-degree flat-fan nozzles are usually mounted on 20-inch centers at a boom height of 17 to 19 inches. One hundred ten-degree nozzles can be mounted on 20 or 30-inch centers, at boom heights of 16 to 18 inches, and 20 to 22 inches, respectively. To achieve maximum uniformity in the spray distribution, regardless of the spacing and height, the spray patterns

should overlap 50 to 60 percent of the nozzle spacing (25 to 30 percent on each edge of the pattern). Foam markers and computer-aided guidance systems are commonly used to help operators with swath width overlap requirements on multiple passes.

For soil applications, the recommended pressure range is 10 to 30 psi. For foliar application in which smaller drops are required to increase coverage, pressures from 30 to 60 psi may be required. The incidence of drift may increase when operating pressures exceed 30 psi. Nozzle wear rate is also increased at higher pressures.

**Flooding Flat-Fan Nozzles (old style nozzle, several manufacturers have similar designs)**

Flooding flat-fan nozzles produce a wide-angle, flat-fan pattern, and are used for applying herbicides, herbicide mixtures, and liquid fertilizers. The nozzle spacing should be 40 inches or less for common sprayer application. When flooding flat-fan nozzles are used for commercial application on “floaters,” 60-inch spacings are used. These nozzles are most effective in reducing drift when they are operated within a pressure range of 10 to 30 psi. Pressure changes affect the width of the spray pattern more with the flooding flat-fan nozzle than with the extended range flat-fan nozzle. In addition, the distribution pattern is usually not as uniform as that of the extended range flat-fan tip. The best distribution is achieved when the nozzle is

mounted at a height and angle that obtains at least double coverage or 100 percent overlap. Uniformity of application depends upon the pressure, height, spacing, and orientation of the nozzles. Pressure directly affects droplet size, nozzle flow rate, spray angle, and pattern uniformity. At low pressures, flooding nozzles produce large spray drops; at high pressures, these nozzles actually produce smaller drops than flat-fan nozzles at an equivalent flow rate.

The spray distribution of flooding nozzles varies greatly with changes in pressure. At low pressures, flooding nozzles produce a fairly uniform pattern across the swath, but at high pressures the pattern becomes heavier in the center, tapering off toward the edge. The width of the spray pattern is also affected by pressure. To obtain an acceptable distribution pattern and overlap, you should operate flooding nozzles within a pressure range of 10 to 30 psi.



*Flooding flat-fan nozzle*

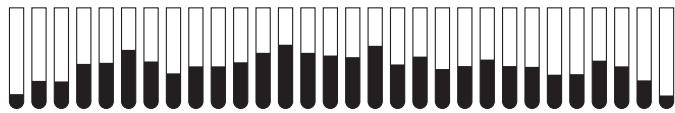

*Flooding flat-fan spray pattern*

Nozzle height is critical in obtaining uniform application when using flooding nozzles. Flooding nozzles can be mounted vertically to spray backwards, horizontally to spray downward, or at any angle between vertical and horizontal. When the nozzle is mounted horizontally to spray downward, heavy concentrations of spray tend to occur at the edges of the spray pattern. Rotating the nozzles 30 to 45 degrees from the horizontal will usually increase pattern uniformity over the recommended pressure range of 10 to 30 psi. For uniform distribution over a range of pressures, mount the nozzles to obtain double coverage at the lowest operating pressure.

### Turbulation Chamber Nozzles

The most recent improvements in nozzle design have incorporated a pre-orifice concept with an internal turbulation chamber. These design changes have resulted in larger, less driftable droplets and improved spray pattern uniformity. Turbulation chamber nozzles are available in flood and flat-fan tip designs.

### Turbo® Flood Nozzles

Turbo® flood nozzles combine the precision and uniformity of extended range flat-fan spray tips with the plugging resistance and wide-angle pattern of older style flooding flat-fan nozzles. The design of Turbo® flood nozzles results in larger droplets and improved distribution uniformity. Turbulence in the chamber portion of the spray tip lowers exit pressure, reducing the formation of small driftable droplets. Exit orifice design changes improve

*Turbo® flood nozzle*

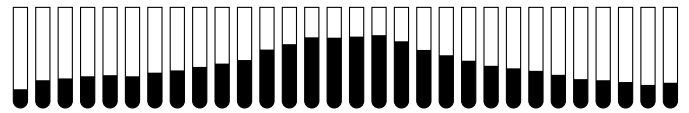
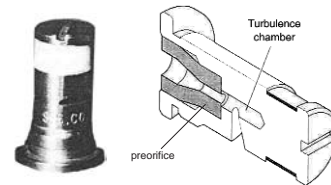

*Turbo® flood spray pattern*

pattern uniformity over older style flooding nozzles. Turbo® flood nozzles are designed to operate at pressures of 10 to 40 psi.

Turbo® flood nozzles require an overlap of at least 50 to 60 percent of the nozzle spacing (25 to 30 percent on each edge of the pattern). The relationship between nozzle pressure, height, and spacing is critical for obtaining uniform application. Typical floater boom configurations have Turbo® flood nozzles spaced on 60-inch centers and range up to 48-inches above the ground. Nozzles can be mounted vertically to spray backward, horizontally to spray downward, or any angle between vertical and horizontal. For uniform distribution, proper overlap is required regardless of the nozzle mounting angle.

Turbo® flood nozzles are highly recommended for soil applications, particularly when applying tank mix combinations of fertilizers and herbicides. Turbo® flood nozzles produce larger droplet spectrums than standard flooding nozzles and work well in drift-sensitive applications.

### Turbo® Flat-Fan Nozzles

The Turbo® flat-fan nozzle design develops a greatly improved spray pattern compared to the extended range flat-fan and other drift reduction flat-fan nozzles. This nozzle was modeled after the Turbo® flood, but for use in the application of postemergence products. Turbo® flat-fan nozzles are wide-angle, pre-orifice nozzles that create larger spray droplets across a wider pressure range (15 to 90 psi) than comparable low-drift tips, reducing the

amount of driftable particles. The unique design of these nozzles allow them to be mounted in a flat-fan nozzle body configuration. The wide spray angle will allow for a 20- or 30-inch nozzle spacing, and requires an overlap of at least 50 to 60 percent of the nozzle spacing (25 to 30 percent on each edge of the pattern) to achieve uniform application across the boom. Position the tip so that the preset spray angle is directed away from the direction of travel. The Turbo® flat-fan nozzle is recommended for use with electronic spray controllers where speed and pressure changes occur regularly.

*Pre-orifice Turbo® flat-fan nozzle*

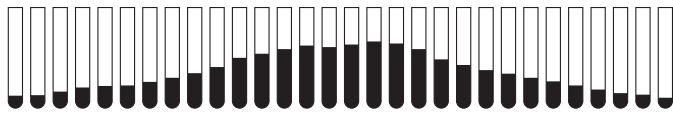
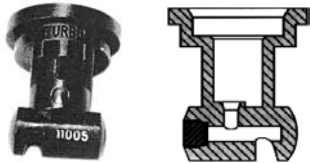

*Turbo® flat-fan spray pattern*

### Turbo® Turf Flood Nozzles

The Turbo® turf flood is a new nozzle designed for the turf industry. It is modeled after the Turbo® flood nozzle, which is used extensively in the application of crop protection products for agricultural field crops. The major difference is that the Turbo® turf flood nozzle incorporates a larger orifice to accommodate heavier application volumes, which are common in the turf boom sprayer industry.



*Turbo® turf flood nozzle*

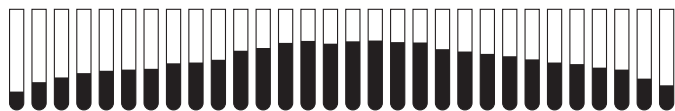

*Turbo® turf flood spray pattern*

Otherwise, this nozzle exhibits the same high quality spray pattern when placed on the boom from 20 to 30 inches apart, and at a height above the turf at 14 to 20 inches. Actual spacing should overlap at least 50 to 60 percent of the nozzle spacing (25 to 30 percent on each edge of the pattern) for a uniform application. As with the field crop version of this nozzle, the Turbo® turf flood has excellent drift control, resulting from the turbulence chamber creating larger spray droplets and less driftable fines. This nozzle may have use in applying certain agricultural products on soil as a replacement for the Raindrop® nozzle.

### Air-Induction/Venturi Nozzles

A recent trend in drift reduction nozzle design is incorporating air into the spray mixture to produce an air-fluid mix. Several different designs are currently being marketed, and are commonly referred to as air-induction or venturi nozzles. Air is entrapped into the spray solution within the nozzle. To accomplish the mixing, an inlet port and venturi is typically used to draw the air into the tip under reduced pressure. The air-fluid mixture forms a larger spray droplet to help transport the droplets to the target. By increasing the size of the spray droplet, spray drift is reduced by minimizing smaller driftable fines. The current design of these tips requires a higher operating pressure to maximize performance. Most all venturi nozzles are designed to spray a wide-angle flat spray pattern.

*Air induction/venturi nozzle*

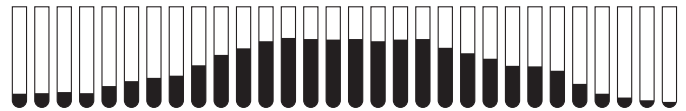
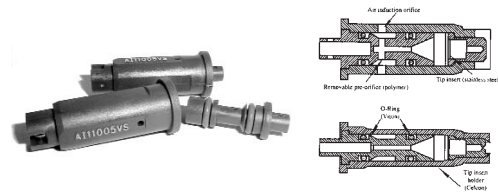

*Air induction/venturi spray pattern*

Venturi nozzles, which are currently more expensive, dramatically reduce the potential for drift. In addition to providing good protection against drift, research indicates they also provide adequate efficacy. The efficacy levels achieved relate closely to coverage and mode of action for the crop protection products being used. It is also important to maintain at least 40 psi as an operating pressure to maintain uniform pattern development while properly atomizing the spray solution.

Please note any special calibration requirements for the venturi nozzles. For example, Greenleaf, designer of the TurboDrop® venturi two-piece nozzle, requires the exit orifice to be two-times (2X) the size of the venturi orifice. Otherwise the exit orifice may create a negative pressure effect in the venturi area, resulting in failure of the nozzle to create the proper spray quality (actually reversing flow from the air inlets). Therefore, you will need to select and calibrate the TurboDrop® nozzle based on the venturi orifice, which is color-coded to meet manufacturing standards. A chart is available from the manufacturer for this purpose. Other venturi nozzle styles are one piece and do not have this precaution.

*TurboDrop® flat-fan nozzle*

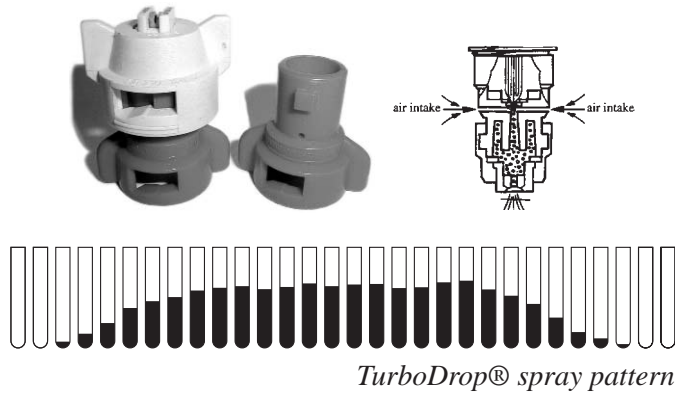

*TurboDrop® spray pattern*

## Nozzle Materials

Spray nozzle assemblies consist of a body, cap, check valve, and nozzle tip. Various types of bodies and caps (including color-coded versions), and multiple nozzle bodies are available with threads as well as quick-attaching adapters. Nozzle tips are interchangeable or molded into the nozzle cap and are available in a variety of materials including hardened stainless steel, stainless steel, brass, ceramic, and various types of plastic. Hardened stainless steel and ceramic are the most wear-resistant materials, but they are also the most expensive. Stainless steel tips have excellent wear resistance with either corrosive or abrasive materials. Plastic tips are resistant to corrosion and abrasion, and are proving to be very economical tips for applying crop protection products. Brass tips have been very common, but are not recommended for use. They wear rapidly when used to apply abrasive materials, such as wettable powders, and are corroded by some liquid fertilizers. Typically, smaller tips with elongated orifices are impacted greatest by wear. Spray tip life is dependent on pressure, how abrasive the spray solution is and other factors, such as corrosion. A “rule-of-thumb” is to change tips when the flow becomes 10 percent greater than in new tips.

Brand names appearing in this publication are for product identification only. No endorsement is intended, nor is criticism implied of similar products not mentioned.

Publications from Kansas State University are available on the World Wide Web at [www.oznet.ksu.edu](http://www.oznet.ksu.edu)

Contents of this publication may be freely reproduced for educational purposes. All other rights reserved. In each case, credit Robert E. Wolf, *Nozzle Types Available for Boom Sprayer Applications of Crop Protection Products*, Kansas State University, April 2002.

## Kansas State University Agricultural Experiment Station and Cooperative Extension Service

MF-2541

April 2002

It is the policy of Kansas State University Agricultural Experiment Station and Cooperative Extension Service that all persons shall have equal opportunity and access to its educational programs, services, activities, and materials without regard to race, color, religion, national origin, sex, age or disability. Kansas State University is an equal opportunity organization. Issued in furtherance of Cooperative Extension Work, Acts of May 8 and June 30, 1914, as amended. Kansas State University, County Extension Councils, Extension Districts, and United States Department of Agriculture Cooperating, Marc A. Johnson, Director.

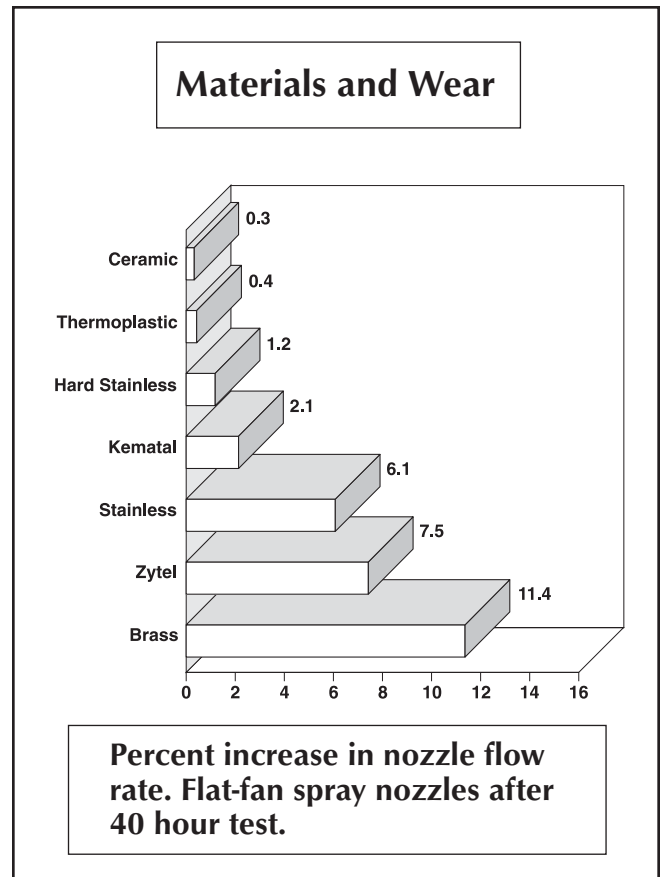

Source: University of Illinois, Agricultural Engineering

Venturi nozzles are typically designed from polymers, and may incorporate stainless or hardened stainless orifice inserts for the actual tip. Many of these nozzles are designed as two-piece units with the pre-orifice removable for easier cleaning.

No one tip will perform well in all of the applications currently being used. Refer to manufacturers' catalogs and web pages for selection and setup assistance. Proper selection and setup will enhance the efficacy and safety of all spray applications. Many chemical labels may specify a specific droplet quality classification in the near future. These are excellent resources to ensure compliance.